

Coax Cable Stripper Suits RG59/RG6

T0063-002



FEATURES

For stripping RG6/U and RG59/U coaxial cables. 3 blades ensure accurate stripping length of each cable section. Built-in hex screws for accurate depth-of-cut adjustment for each blade. Preset stripping length of 12mm (8mm + 4mm). Blades may be repositioned to give a 10mm (6mm + 4mm) stripped length. Reversible cutting block for quick change when stripping between RG6/U and RG59/U coaxial cables.

DESIGN & CONSTRUCTION

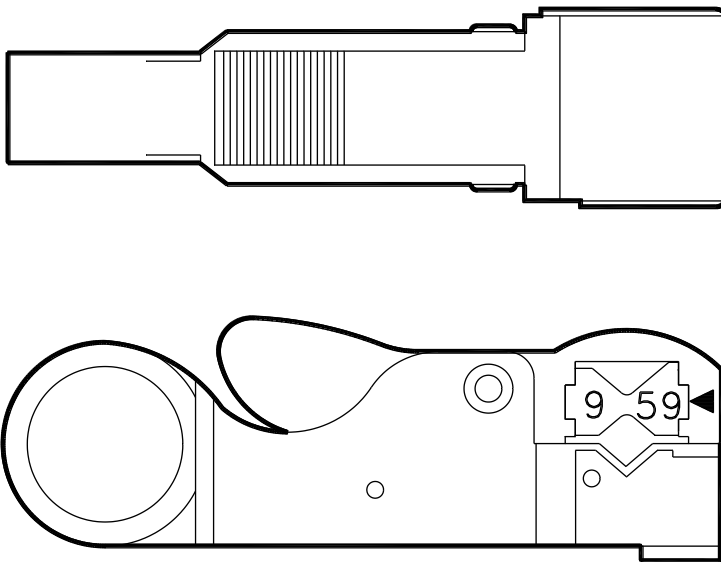

1. The V-block can be reversed, and the arrow "►" indicates the (RG) cable size.
2. Adjust the stripper distance by shifting one of the stripping blades.
3. Rotate the stripper 3-6 times clockwise to simultaneously strip the coaxial jacket and inner conductor.
4. For stripping different material of cable use the built in hex. The sensitive socket must be in alignment and the blade adjusted for good results.

MATERIAL CHARACTERISTICS

Length	4.3" (108mm)
Weight	50g
Material	Body - made of ABS Blade - made of SK-5

To view Access' extensive ranges go to: www.accesscomms.com.au

Sydney (Head Office)
Brisbane Sales
Melbourne Office
Adelaide Office

Unit 1, 29 Prince William Drive, Seven Hills NSW 2147
28 The Gateway, Broadmeadows VIC 3047
71 Anzac Highway, Ashford SA 5035

Phone: (02) 9414 8888
Phone: (07) 3308 5555
Phone: (03) 9330 8333
Phone: (08) 8338 5540

sales@accesscomms.com.au
brisbane@accesscomms.com.au
melbourne@accesscomms.com.au
adelaide@accesscomms.com.au