

Cat5e & Cat6 Clear Boots

P7850CLUJ

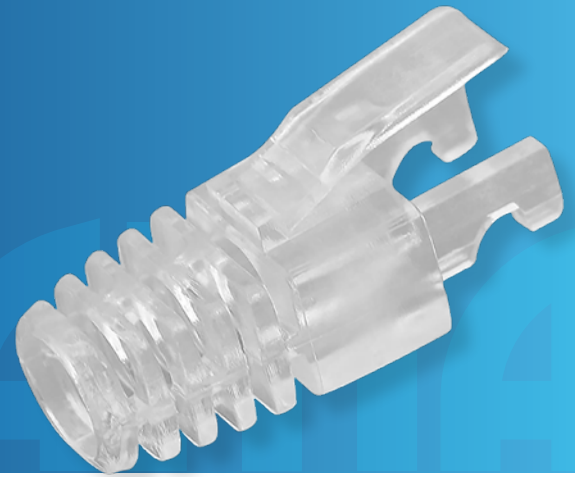

FEATURES

Cat5e and Cat6 Modular Clear boots add a tougher extensions to the end of the cable connectors. The boots protect against cable bending from the point of termination. Adding a clear boot to the end of the termination point can increase the longevity of modified cables. This boot is also additional protection against cable fraying and internal wire stretching from bending cables.

CAT#	TYPE	COLOUR	PACKING
P7850CLUJ	Cat5e & Cat6	Clear	Jar of 100

DESIGN & CONSTRUCTION

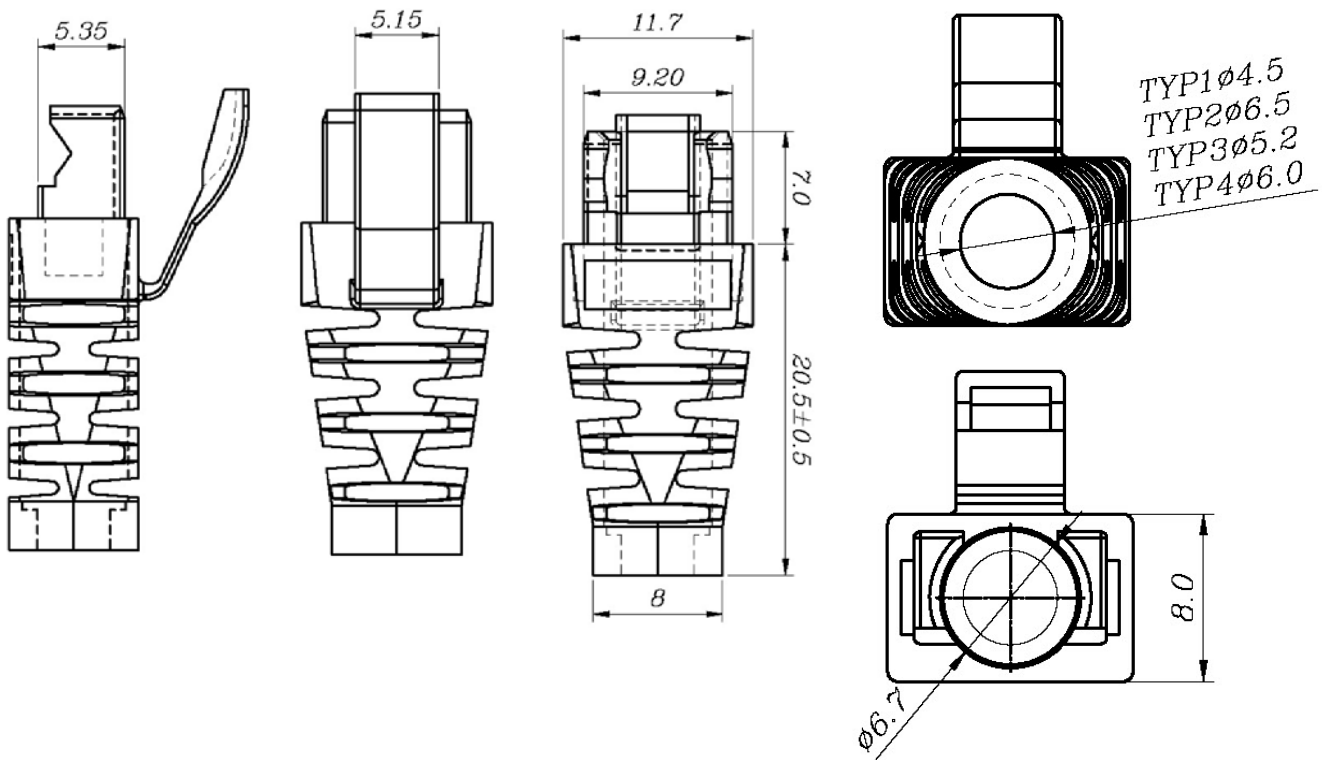

To view Access' extensive ranges go to: www.accesscomms.com.au

Sydney (Head Office)
Brisbane Sales
Melbourne Office
Adelaide Office

Unit 1, 29 Prince William Drive, Seven Hills NSW 2147
28 The Gateway, Broadmeadows VIC 3047
71 Anzac Highway, Ashford SA 5035

Phone: (02) 9414 8888
Phone: (07) 3308 5555
Phone: (03) 9330 8333
Phone: (08) 8338 5540

sales@accesscomms.com.au
brisbane@accesscomms.com.au
melbourne@accesscomms.com.au
adelaide@accesscomms.com.au

Cat5e & Cat6 Clear Boots

P7850CLUJ

MATERIAL

Housing	Polycarbonate, UL94V-2
Housing Colour	Transparent

SUITS

Suits stranded and solid conductors 22 - 23 AWG



To view Access' extensive ranges go to: www.accesscomms.com.au

Sydney (Head Office)
Brisbane Sales
Melbourne Office
Adelaide Office

Unit 1, 29 Prince William Drive, Seven Hills NSW 2147
28 The Gateway, Broadmeadows VIC 3047
71 Anzac Highway, Ashford SA 5035

Phone: (02) 9414 8888
Phone: (07) 3308 5555
Phone: (03) 9330 8333
Phone: (08) 8338 5540

sales@accesscomms.com.au
brisbane@accesscomms.com.au
melbourne@accesscomms.com.au
adelaide@accesscomms.com.au