

Cat6A RJ45 Waterproof Coupler

P2328



FEATURES

- Cat6a RJ45 Waterproof Inline Coupler used to join two Cat6a cables together easily.
- Simple assembly to implement connector into existing cabling system.

DESIGN & CONSTRUCTION

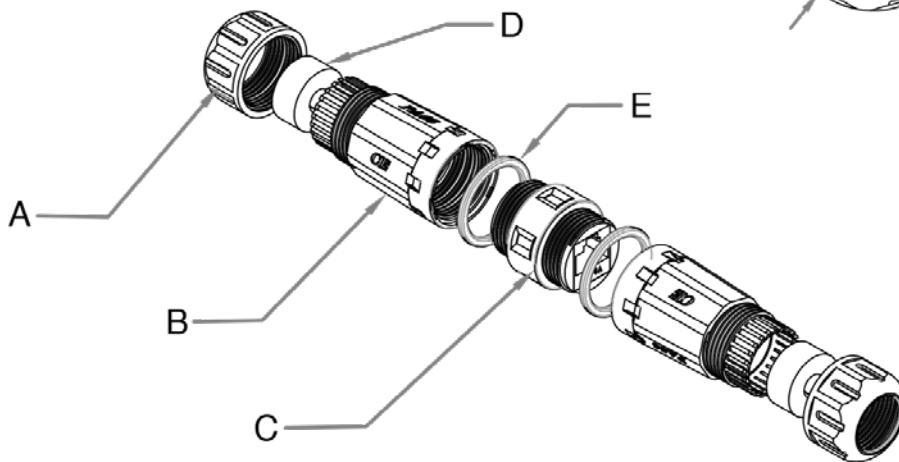
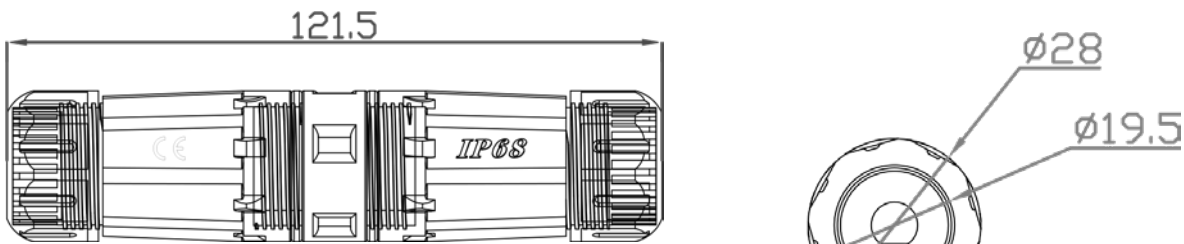

Item	Description
A	Tail Cover
B	Long Middle cover
C	Network subject
D	Rubber ring
E	Silicone ring

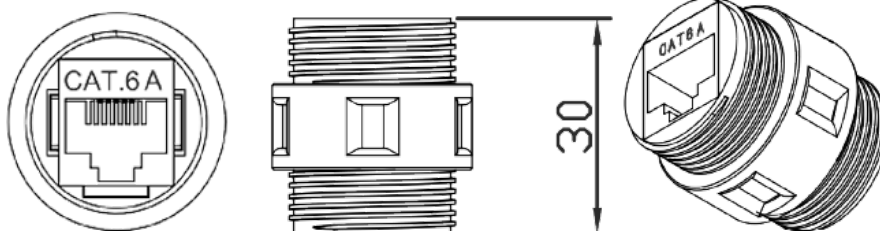

To view Access' extensive ranges go to: www.accesscomms.com.au

Sydney (Head Office)
Brisbane Sales
Melbourne Office
Adelaide Office

Unit 1, 29 Prince William Drive, Seven Hills NSW 2147

28 The Gateway, Broadmeadows VIC 3047
71 Anzac Highway, Ashford SA 5035

Phone: (02) 9414 8888
Phone: (07) 3308 5555
Phone: (03) 9330 8333
Phone: (08) 8338 5540

sales@accesscomms.com.au
brisbane@accesscomms.com.au
melbourne@accesscomms.com.au
adelaide@accesscomms.com.au

Cat6A RJ45 Waterproof Coupler P2328

ELECTRICAL SPECIFICATIONS

Voltage Rating	125 VAC RMS
Current Rating	1.5 AMP
Contact Resistance	100 Milli Ω Max
Insulation Resistance	1000Meg Ω Min at 500 VDC
Dielectric Strength	750 VAC RMS 60Hz 1 Min

TOLERANCE

0.00 - 20.00	± 0.10
20.00 - 50.00	± 0.15
50.00 - 100.00	± 0.20
100.00	± 0.25
Angle	± 0.30

MECHANICAL

Housing Material	PA66
Insert Material	Flame retardant
PCB Material	FR - 4 T = 1.6mm
RJ45 Jack contact	Phosphor Bronze with Nickel Plating gold plated (50U)
RJ45 Jack life	750 x insertion cycle
Waterproof grade	IP68

ENVIRONMENTAL

Storage	-40°C to +85°C
Operation	0°C to 70°C

REGULATORY COMPLIANCE



To view Access' extensive ranges go to: www.accesscomms.com.au

Sydney (Head Office)
Brisbane Sales
Melbourne Office
Adelaide Office

Unit 1, 29 Prince William Drive, Seven Hills NSW 2147
28 The Gateway, Broadmeadows VIC 3047
71 Anzac Highway, Ashford SA 5035

Phone: (02) 9414 8888
Phone: (07) 3308 5555
Phone: (03) 9330 8333
Phone: (08) 8338 5540

sales@accesscomms.com.au
brisbane@accesscomms.com.au
melbourne@accesscomms.com.au
adelaide@accesscomms.com.au