

Sliding Cabinet Shelf

C1024



FEATURES

Vented sliding shelf to suit our Datamaster® Server/Network cabinets C1800 & C1400. Use C1023 Cage Nuts to secure to the rack cabinet. Provides easy access for laptop or other equipment. Black powder coated finish.

CAT#	SUITS CABINETS
C1024-606	C1400 Series, 600mm deep
C1024-808	C1400, C1800 Series, 800mm deep
C1024-810	C1400, C1800 Series, 1000mm deep
C1024-812	C1800 Series, 1200mm deep



To view Access' extensive ranges go to: www.accesscomms.com.au

Sydney (Head Office)
Brisbane Sales
Melbourne Office
Adelaide Office

Unit 1, 29 Prince William Drive, Seven Hills NSW 2147
28 The Gateway, Broadmeadows VIC 3047
71 Anzac Highway, Ashford SA 5035

Phone: (02) 9414 8888
Phone: (07) 3308 5555
Phone: (03) 9330 8333
Phone: (08) 8338 5540

sales@accesscomms.com.au
brisbane@accesscomms.com.au
melbourne@accesscomms.com.au
adelaide@accesscomms.com.au

Sliding Cabinet Shelf

C1024

DESIGN & CONSTRUCTION

C1024-812

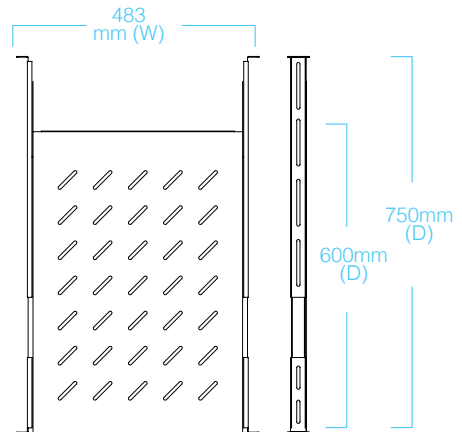
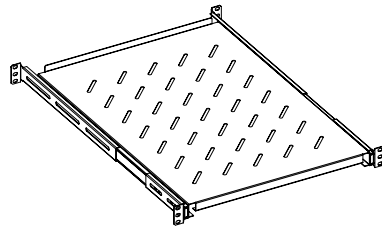

C1024-810

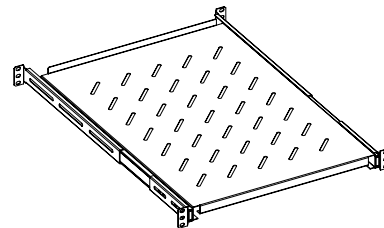
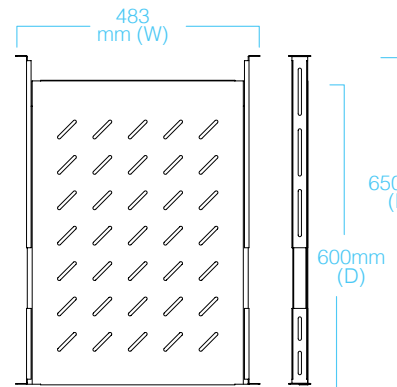

C1024-808

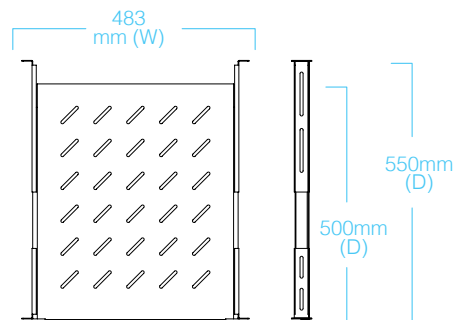
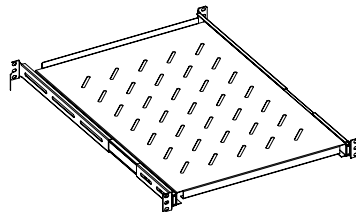

C1024-806

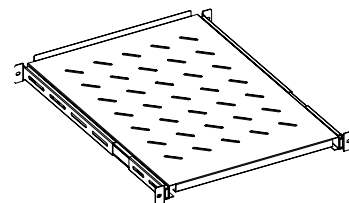
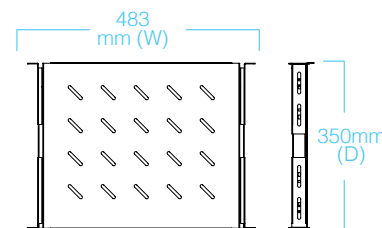

To view Access' extensive ranges go to: www.accesscomms.com.au

Sydney (Head Office)
Brisbane Sales
Melbourne Office
Adelaide Office

Unit 1, 29 Prince William Drive, Seven Hills NSW 2147
28 The Gateway, Broadmeadows VIC 3047
71 Anzac Highway, Ashford SA 5035

Phone: (02) 9414 8888
Phone: (07) 3308 5555
Phone: (03) 9330 8333
Phone: (08) 8338 5540

sales@accesscomms.com.au
brisbane@accesscomms.com.au
melbourne@accesscomms.com.au
adelaide@accesscomms.com.au