

Cat # T0500 Powermaster® 500mA Multi-voltage Adaptor

ELECTRICAL CHARACTERISTICS

Input	Output			
	Rated Voltage	Rated Current	No-load voltage	Ripple (rms)
240VAC 50Hz	1.5Vdc ±5%	500mA	3.7Vdc maximum	- mV
240VAC 50Hz	3.0Vdc ±5%	500mA	6.0Vdc maximum	- mV
240VAC 50Hz	4.5Vdc ±5%	500mA	8.0Vdc maximum	- mV
240VAC 50Hz	6.0Vdc ±5%	500mA	10.0Vdc maximum	- mV
240VAC 50Hz	7.5Vdc ±5%	500mA	12.0Vdc maximum	- mV
240VAC 50Hz	9.0Vdc ±5%	500mA	14.0Vdc maximum	- mV
240VAC 50Hz	12.0Vdc ±5%	500mA	18.0Vdc maximum	- mV

Hi-pot Test: 4kV 50Hz for one minute between input and output circuit. No flashover or breakdown shall occur during the test.

Insulation Test: 500VDC applied for one minute between input and output circuit. The insulation resistance shall be not less than 100MΩ.

Temperature Rise: 85°C max, primary winding with output full load (R of R method).

Output Jack Type: 8 in 1 jack set.

Output Jack Wire: 24AWG x 1.8m round cable.

Circuit Diagram:

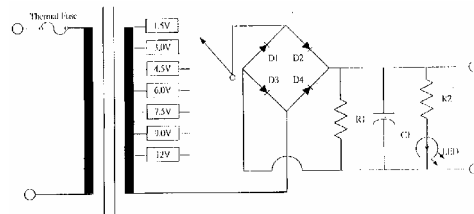

MECHANICAL CHARACTERISTICS

Strain Relief Test: A 89N force is to be applied to the cord or output cord for one minute without displacement deformation of its anchoring surface. The strain relief shall not be acceptable if there is any movement of the cord to indicate that stress on the connections would have resulted.

Drop Test: Three samples are to be dropped (free fall) three times in succession from a height of 914mm onto a hardwood surface. After completion of the drop test, each sample is to be subjected to the Hi-Pot Test. No flashover or insulation breakdown shall have occurred.

Direct Plug-in Blade Secureness Test: Each blade and grounding pin shall withstand a direct pull of 89N for two minutes without loosening.

Detachable plug dimensions:

Type	ID(mm)	OD(mm)	Length (mm) max.	Colour dot
Mono Phono		2.50	12.50	Black
Mono Phono		3.50	14.00	White
DC Plug	2.10	5.00	14.00	Dark green
DC Plug	2.50	5.50	14.00	Light Green
DC Plug	1.30	3.50	11.50	Red
DC Plug	2.10	5.50	12.00	Dark Blue
EIAJ Plug	0.70	2.33	10.00	Brown
EIAJ Plug	1.75	4.75	9.50	Orange

Cat # T0500 Powermaster® 500mA Multi-voltage Adaptor

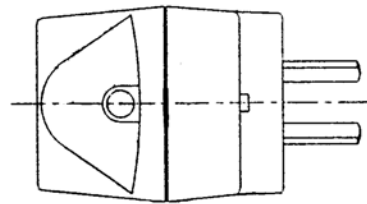
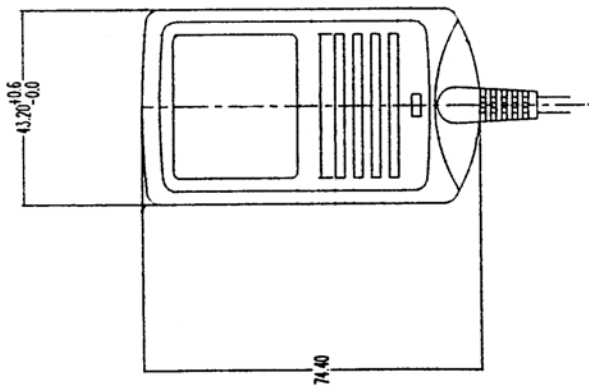
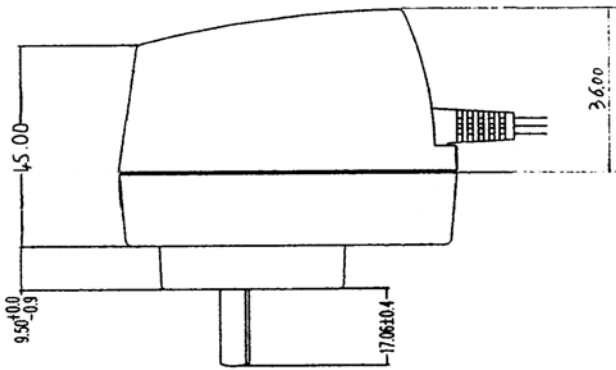
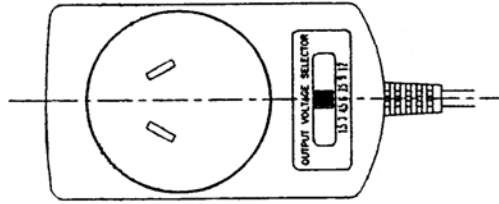

PRODUCT ADAPTER	TITLE	MODEL NO. T0500	
PART NAME	QTY. /	PART NO.	PAGE / OF /
MAT'L	SHRINK	SCALE:	DRAWN
FINISH			CHKD